

**ecostore**  
**2 Door Dual Digital Refrigerator,**  
**1430lt (-2/-22), AISI 304 - R290**

ITEM # \_\_\_\_\_

MODEL # \_\_\_\_\_

NAME # \_\_\_\_\_

SIS # \_\_\_\_\_

AIA # \_\_\_\_\_

**725365 (REX142FDD)**

 2-door dual temperature  
 Refrigerator/Freezer  
 1430lt, -2+10°C / -22-15°C,  
 digital, AISI 304, R290

### Short Form Specification

**Item No.** \_\_\_\_\_

Two full door refrigerator with internal and external structure in 304 AISI stainless steel; external back panel in galvanized steel and bottom panel in anti-corrosive material. Digital control with cabinet temperature display and setting and manual activation of defrost cycle. Fully compliant HACCP digital controls include visible alarms. Optimized back to front forced air flow provides even temperature distribution and fast cooling in any conditions. Fitted with 75 mm-thick cyclopentane insulating foam. Door features lock and door microswitch to switch off the fan when the door is opened. Hidden evaporator to guarantee higher storage capacity and less corrosion problems. Built-in refrigeration unit; ventilated operation; automatic defrost and evaporation of defrost water. Dual operating temperature: -2/+10° C -15/-22°C. CFC and HCFC free. Integrated RS485 port to facilitate connection to a remote computer and integrated HACCP systems. R290 gas in refrigeration circuit.

### Main Features

- Large storage area suitable to contain 2/1 GN grids or shelves on anti-tilt runners.
- Optimized back to front forced air flow provide even temperature distribution and fast cooling in any conditions.
- Automatic defrost.
- Internal structure with numerous charging positions available to host grids, ensuring higher net capacity and a greater storage space.
- Cabinet fitted with up to 75 mm thickness of cyclopentane insulation for best insulating performance with 100% environmental protection (thermal conductivity: 0,020 W/m\*K).
- 60 mm-thick insulation covering the evaporator can be easily removed with a single operation.
- Hidden evaporator thus guaranteeing higher storage capacity and less corrosion problems.
- Equipped with single phase electrical cable and Schuko plug for easy and fast installation.
- Right hinged full door.
- Tropicalized unit.

### Construction

- Constructed from the highest quality AISI 304 Stainless steel.
- Stainless steel runners and supports easily disassembled.
- Anti-corrosion bottom material avoids any damage that may be caused to the cabinet by aggressive detergents employed to clean the floors.
- Easy access to the main components for maintenance.
- Lockable door.
- Mounted on adjustable Stainless steel feet, with castors as an option.
- Doors are self-closing and can be fully opened up to 180°.
- The rounded internal corners, the easily removable runners and grids allow for ease of cleaning and high hygiene standards.

### User Interface & Data Management

- Integrated RS485 port to facilitate connection to a remote computer and integrated HACCP systems.
- Easy serviceability thanks to the intuitive control panel with access via app.
- Large digital white-digit display with cabinet temperature display and setting, activation of turbo frost cycle (to rapidly cool warm loads) and possibility to activate manually the defrost cycle.

### Sustainability

- Door switch stops the fan when door is opened to avoid cold air exiting the cell, thus saving energy.
- Removable triple-chamber balloon magnetic gasket to improve insulation and reduce energy consumption and ease of cleaning.

**APPROVAL:** \_\_\_\_\_

- Automatic evaporation of the defrosting water by hot gas on the top for energy saving.
- CFC and HCFC free, highly ecological refrigerant type: R290 (ecological gas in foam: cyclopentane). Hydrocarbon refrigerant gas R290 for the lowest environmental impact (GWP=3), to reduce green house and ozone depletion effects.
- Cleaning-free condenser: the structure of the wire frame condenser prevents dust and grease accumulation thus avoiding periodical cleaning operations and reducing energy consumption.

### Included Accessories

- 6 of 2/1GN grey rilsan grid with 2 runners PNC 881020

### Optional Accessories

- 2 stainless steel runners for refrigerated cabinets - (Marine) PNC 880242
- Set of 8 GN1/1 PVC containers for fish PNC 880243
- Spacer for 670 lt and 1430 lt refrigerated cabinets PNC 880248
- Kit 20 pair runners and tray supports to fit pastry trays (400x600mm) PNC 880333
- Kit of 6 swivelling wheels, 2 with brake, diam 50 mm PNC 880340
- Kit remote alarm PNC 880570
- Ethernet connectivity kit IJF for Refrigeration PNC 880685
- 1/1GN plastic container with false bottom PNC 880705
- 2/1GN grey rilsan grid PNC 881004
- 2/1GN aisi 304 stainless steel grid PNC 881016
- 2/1GN 304 AISI stainless steel grid with 2 runners PNC 881018
- 2/1GN grey rilsan grid with 2 runners PNC 881020
- Set of 2 stainless steel runners for 670/1430lt refrigerators and freezers PNC 881021
- Pedal opening for 1430lt refrigerator PNC 881033
- 2/1GN pvc container with lid and 2 runners PNC 881039
- 2/1GN perforated shelf PNC 881042
- 1/1GN rilsan steel wire basket h=150mm PNC 881043
- 3 grey rilsan central grids for 1430lt (not for glass door) PNC 881044
- 2/1GN grey rilsan basket+2 runners h=150mm PNC 881047
- 5 swivelling wheels (2 with brake), diam 125mm, for 1430 lt refrigerators, NOT for remote models PNC 881294
- IoT module for refrigerated cabinets and counters PNC 881298
- POE switch PNC 922432

### Recommended Detergents

- S01 STAINLESS STEEL SURFACE POLISHER; 6 BOTTLES X 750ML C/T PNC 0S2881
- S05 - MULTIPURPOSE DEGREASER; 6PCS X 750ML; ADR&IMDG Limited Quantity PNC 0S3257

Front

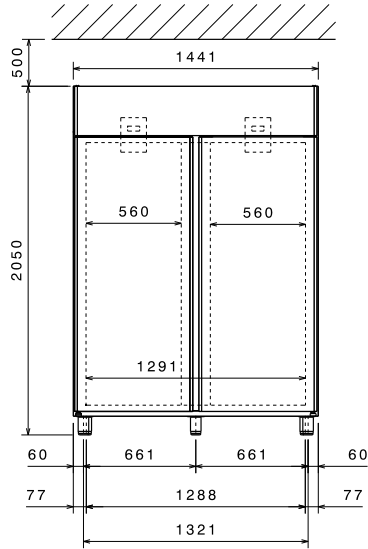

Side

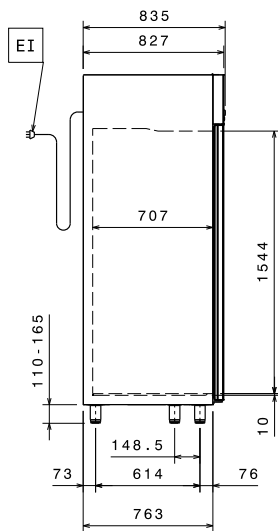

EI = Electrical inlet (power)

Top

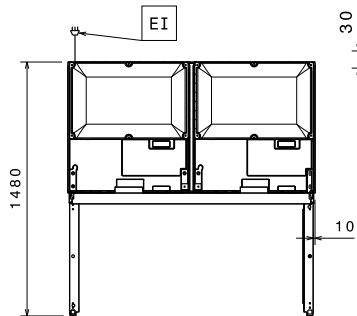

### Electric

Supply voltage: 220-240 V/1 ph/50 Hz  
 Electrical power, max: 0.7 kW

### Capacity:

Number and type of grids (included): 6 - GN 2/1

### Key Information:

Net Volume: 1006 lt  
 Door hinges:  
 External dimensions, Width: 1441 mm  
 External dimensions, Depth: 835 mm  
 External dimensions, Depth with Doors Open: 1480 mm  
 External dimensions, Height: 2050 mm  
 Number and type of doors: 2 Full  
 Type of external material: 304 AISI  
 Type of internal material: 304 AISI  
 Internal panels material: 304 AISI  
 Number of positions & pitch: 44; 30 mm  
 Gross capacity: 1430 lt

### Refrigeration Data

Second Unit - Refrigerant Type: R404a  
 Control type: Digital  
 Refrigeration power at evaporation temperature: -10 °C  
 Operating temperature - First Unit (min-max): -2°C / 10°C  
 Operating temperature - Second Unit (min-max): -15°C / -22°C  
 Operating mode: Ventilated

### ISO Certificates

ISO Standards: ISO 9001; ISO 14001; ISO 45001; ISO 50001

### Sustainability

Refrigerant type: R290